

# Incremental encoders

Through hollow shaft  $\varnothing 28$  to  $\varnothing 30$  mm  
1024...10000 pulses per revolution

## ITD 41 A 4 Y68



ITD 41 A 4 Y68 with through hollow shaft

### Features

- Encoder with through hollow shaft  $\varnothing 28...30$  mm
- Max. 10000 pulses per revolution
- Optical sensing method
- Mounting by torque support
- TTL or HTL output signals
- Cable output radial

### Optional

- Cable with connector
- Extended operating temperature range

### Technical data - electrical ratings

Voltage supply	5 VDC $\pm 5\%$ 8...30 VDC
Reverse polarity protection	Yes
Consumption w/o load	$\leq 100$ mA
Pulses per revolution	1024...10000
Reference signal	Zero pulse, width $90^\circ$
Sensing method	Optical
Output frequency	$\leq 300$ kHz (TTL) $\leq 160$ kHz (HTL)
Output signals	A, B, N + inverted
Output stages	TTL linedriver (short-circuit proof) HTL push-pull (short-circuit proof)
Interference immunity	DIN EN 61000-6-2
Emitted interference	DIN EN 61000-6-3

### Technical data - mechanical design

Size (flange)	$\varnothing 80$ mm
Shaft type	$\varnothing 28...30$ mm (through hollow shaft)
Mounting kit	050
Protection DIN EN 60529	IP 65
Operating speed	$\leq 5000$ rpm $\leq 3000$ rpm IP 65 ( $>70^\circ\text{C}$ )
Starting torque	$\leq 0.01$ Nm ( $+20^\circ\text{C}$ )
Materials	Housing: aluminium, black, powder-coated Shaft: stainless steel
Operating temperature	$-20...+70^\circ\text{C}$ $-20...+100^\circ\text{C}$
Relative humidity	90 % non-condensing
Resistance	DIN EN 60068-2-6 Vibration 10 g, 55-2000 Hz DIN EN 60068-2-27 Shock 30 g, 11 ms
Connection	Cable 1 m
Weight approx.	580 g



**Part number**

ITD 41 A 4 Y68 

		NI	KR1			050
--	--	----	-----	--	--	-----

Mounting kit  
050 Mounting kit 050

Protection  
IP54 IP 54  
IP65 IP 65

Through hollow shaft  
28  $\varnothing 28$  mm, clamping ring  
29  $\varnothing 29$  mm, clamping ring  
30  $\varnothing 30$  mm, clamping ring

Operating temperature  
S -20...+70 °C  
E -20...+100 °C

Connection  
KR1 Cable 1 m, radial

Output signals  
NI A, A inv, B, B inv, 0, 0 inv

Voltage supply / signals  
T 5 VDC / TTL level, linedriver  
H 8...30 VDC / HTL level, push-pull  
R 8...30 VDC / TTL level, linedriver

Pulse number - see table

**Pulse number**

1024	2048	3072	4096	10000
2000	2500	3600	5000	

# Incremental encoders

Through hollow shaft  $\varnothing 28$  to  $\varnothing 30$  mm  
1024...10000 pulses per revolution

## ITD 41 A 4 Y68

### Output signals

Clockwise rotation when looking at the mounting side.

NI-Output signals

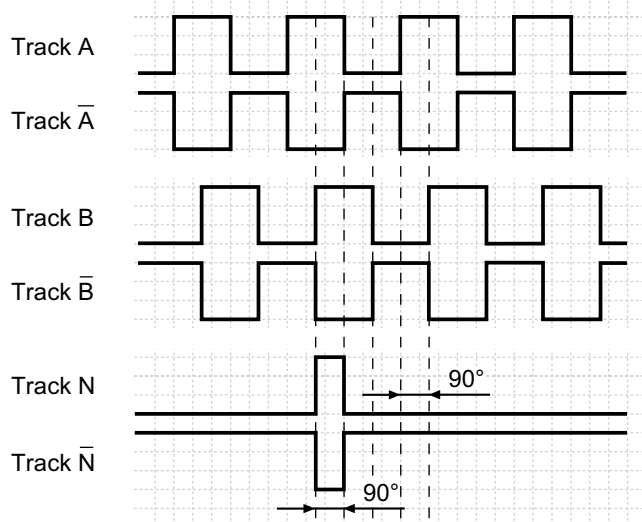

### Terminal assignment

Core colour	Assignment
brown	Track A
green	Track A inv.
grey	Track B
pink	Track B inv.
red	Track N
black	Track N inv.
brown 0,5 mm <sup>2</sup>	UB
white 0,5 mm <sup>2</sup>	GND
blue	UB-Sense
white	GND-Sense
transparent	Shield/Housing

### Trigger level

Outputs	Linedriver
Output level High	$\geq 2.4$ V
Output level Low	$\leq 0.5$ V
Load	$\leq 70$ mA

### Outputs

Outputs	Push-pull short-circuit proof
Output level High	$\geq UB - 3$ V
Output level Low	$\leq 1.5$ V
Load	$\leq 70$ mA

### Dimensions

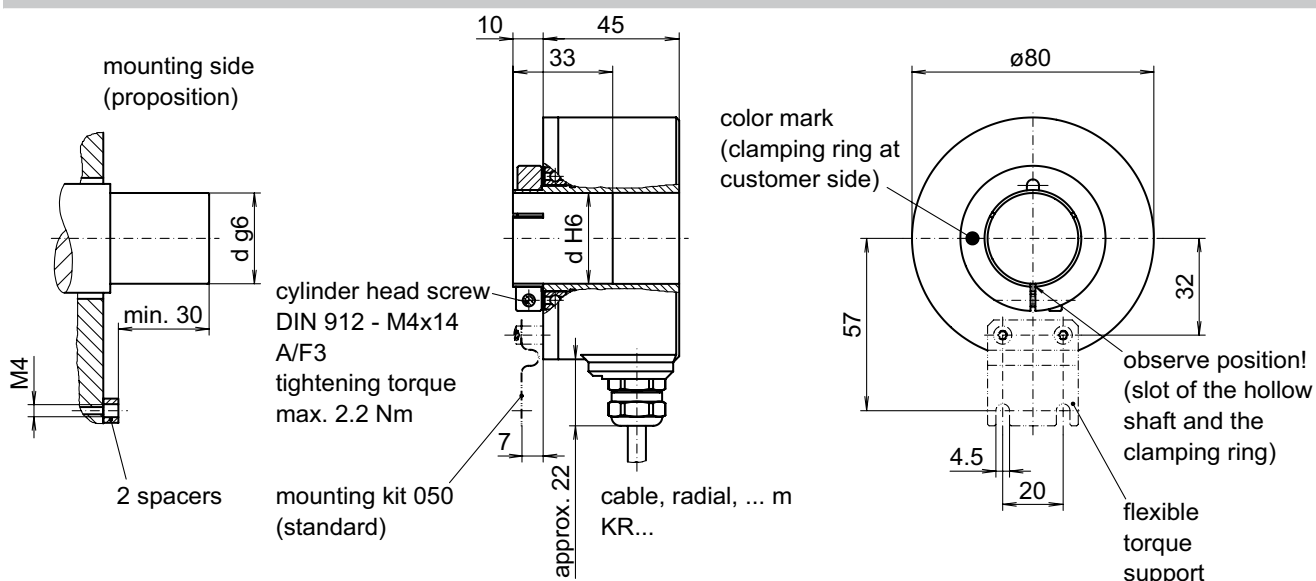

026- 5 Y68



**RAD ELECTRIC Int.**  
www.radelectric.co

# Incremental encoders

Through hollow shaft  $\varnothing 28$  to  $\varnothing 30$  mm  
1024...10000 pulses per revolution

**ITD 41 A 4 Y68**

---