

Incremental encoders

Blind hollow shaft $\varnothing 12$ mm and $\varnothing 14$ mm
64...2048 pulses per revolution

HOG 71



HOG 71

Features

- Blind hollow shaft $\varnothing 12...14$ mm
- Optical sensing method
- Compact, robust die-cast housing
- Inside connecting terminals
- Output stage HTL or TTL
- Output stage TTL with regulator UB 9...26 VDC
- High resistance to shock and vibrations
- High protection IP 66

Technical data - electrical ratings

Voltage supply	9...26 VDC 5 VDC ± 5 %
Consumption w/o load	≤ 100 mA
Pulses per revolution	64...2048
Phase shift	$90^\circ \pm 20^\circ$
Duty cycle	40...60 %
Reference signal	Zero pulse, width 90°
Sensing method	Optical
Output frequency	≤ 120 kHz
Output signals	A, B, C + inverted
Output stages	HTL TTL/RS422
Interference immunity	EN 61000-6-2
Emitted interference	EN 61000-6-3
Approvals	CE, UL approval / E256710

Technical data - mechanical design

Size (flange)	$\varnothing 60$ mm
Shaft type	$\varnothing 12...14$ mm (blind hollow shaft)
Admitted shaft load	≤ 30 N axial ≤ 40 N radial
Protection DIN EN 60529	IP 66
Operating speed	≤ 10000 rpm (mechanical)
Operating torque typ.	1 Ncm
Rotor moment of inertia	55 gcm ²
Materials	Housing: aluminium die-cast Shaft: stainless steel
Operating temperature	$-20...+85$ °C
Resistance	IEC 60068-2-6 Vibration 10 g, 10-2000 Hz IEC 60068-2-27 Shock 100 g, 6 ms
Explosion protection	II 3 G Ex nA IIC T4 Gc X (gas) II 3 D Ex tc IIIC T85°C Dc X (dust)
Connection	Connecting terminal
Weight approx.	280 g



Incremental encoders

Blind hollow shaft ø12 mm and ø14 mm
64...2048 pulses per revolution

HOG 71

Part number

Incremental encoder

HOG71 **DN**

Shaft diameter
 12H7 Blind hollow shaft ø12 mm
 14H7 Blind hollow shaft ø14 mm

Voltage supply / signals
 CI 9...26 VDC / output stage HTL (C) with inverted signals
 TTL 5 VDC / output stage TTL with inverted signals
 R 9...26 VDC / output stage TTL with inverted signals

Pulse number - see table

Output signals
 DN A, B, C + inverted

Pulse number

64	192	360	512	1024
100	200	400	720	2048
180	256	500	1000	

Other pulse numbers on request.

Accessories

Connectors and cables

HEK 8 Sensor cable for encoders

Diagnostic accessories

11075858 Analyzer for encoders HENQ 1100

Subject to modification in technic and design. Errors and omissions excepted.

Incremental encoders

Blind hollow shaft $\varnothing 12$ mm and $\varnothing 14$ mm

64...2048 pulses per revolution

HOG 71

Output signals

At positive rotating direction

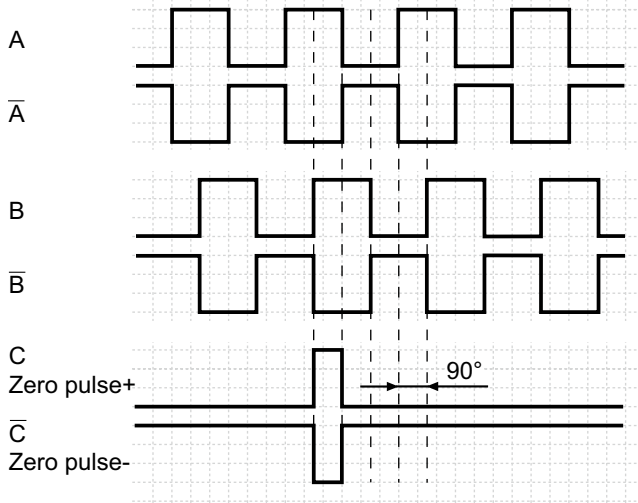

Terminal assignment

View A - Connecting terminal

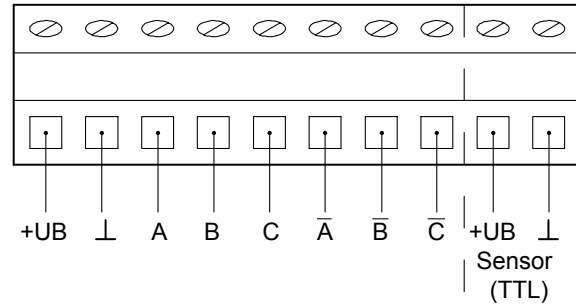

Terminal significance

+UB	Voltage supply (for the device)
⊥; ↓; GND; 0 V	Ground (for the signals)
⊥; ↘	Earth ground (housing)
K1; A; A+	Output signal channel 1
K1; A-bar; A-	Output signal channel 1 inverted
K2; B; B+	Output signal channel 2 (offset by 90° to channel 1)
K2; B-bar; B-	Output signal channel 2 (offset by 90° to channel 1) inverted
K0; C; R; R+	Zero pulse (reference signal)
K0; C-bar; R-bar; R-	Zero pulse (reference signal) inverted
dnu	Do not use



Dimensions

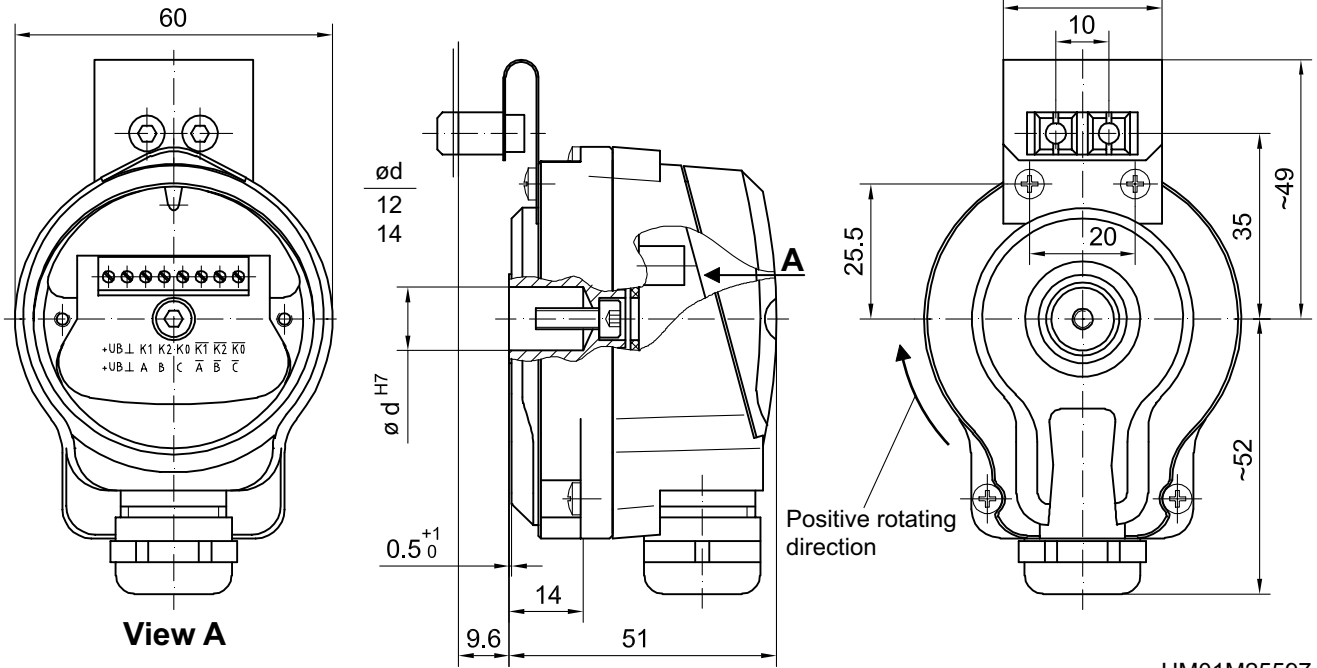

HM01M25597